



You like knowing our logistics  
 redefine what's possible.

[www.airbridgecargo.com](http://www.airbridgecargo.com)



CARGO*iQ*

IOSA Registered Operator





*« It's so rewarding to be part of a team that values tried and true industry principles but combines them with innovative ideas. It's this mindset that allows us to keep growing and take our customers' businesses anywhere they want to be. That's why I love my job. »*

## You like reaching new heights.



### AirBridgeCargo Airlines at-a-glance

AirBridgeCargo Airlines (ABC) was launched in 2004 as a division of Volga-Dnepr Group to perform international scheduled cargo services. Today, it is one of the leading international cargo airlines and a recognized leader in the Russian market. ABC transports its customers' freight all over the world, connecting shippers and consignees in Asia, Europe, North America, and Russia.

Throughout its development, the airline has achieved strong growth, reporting a compound average tonnage increase of 12% in the last five years. ABC's remarkable performance is based on its focus and determination to build long-term relationships with customers around the world and deliver best-in-class service, both in the air and on the ground. The airline is committed to operating to the highest industry standards.







You like being connected to the world.



## AirBridgeCargo Airlines in Asia

Asia was the very first region that welcomed the newly formed cargo airline back in 2004 when AirBridgeCargo's initial B747 flight took off from Moscow on its way to Beijing, China. Since then, the airline has been expanding its presence in Asia by launching flights to Shanghai in 2004, Hong Kong in 2006, Tokyo (Narita) in 2007, Seoul and Zhengzhou in 2010, Chengdu in 2012, Singapore and Hanoi in 2015, and Chongqing and Phnom Penh in 2016. AirBridgeCargo has been focused on gaining customers' trust and reliability by providing effective air cargo services and connecting customers to the world's largest markets in Europe and later in the USA. During the last five years ABC's compound average tonnage from Asia increased by 11%.

Today AirBridgeCargo Airlines is a sound name in Asia associated with quality, unparalleled service and international expertise.

Please contact your nearest customer service manager for more detailed schedule information.







## You like achieving your goals.

« Exceeding expectations is one of our cardinal rules. I go above and beyond to make sure we meet the needs of our customers – their success is our success. That's why I love my job. »

### We put our customers first in everything we do

Understanding the needs of our clients is one of the major contributing factors in the company's development and meeting these requirements is the goal of the more than 900 ABC employees worldwide. Our commitment to delivering highly reliable services is achieved by:

- Operating a modern cargo fleet
- Presenting a greater choice of transportation opportunities by continually expanding ABC's global route network
- Creating confidence and trust in ABC's ability to consistently maintain the highest quality of service
- Investing in a professional, global team of experts based in every region

AirBridgeCargo has been recognized with a series of leading industry awards for the quality of its performance.

### Awards



'Wings of Russia' Award  
'Cargo Carrier of the Year'  
for 4 consecutive years

Anama Quality Awards 2016  
'Quality Overall Performance'



Asian Freight and Supply  
Chain Awards, 2014  
'Best All-Cargo Carrier'

AFLAS (The Asian Freight, Logistic  
and Supply Chain Awards) 2016  
Asia Cargo News - 'Best All-Cargo  
Airline'



Cargo Airline  
of the Year Awards, 2015  
'All-Cargo Airline of the Year'

Payload Asia Awards 2016  
'Media Award of the Year'





# You like setting standards.

## Loading dimensions of B747-8F

Maximum takeoff weight: 442,220 kg | 975,000 lb | Maximum landing weight: 344,280 kg | 759,000 lb



### AirBridgeCargo operates a modern, efficient and capable fleet of Boeing 747 freighters.

Currently, its fleet consists of 16 Boeing 747 freighters, comprising five Boeing 747-400ERFs, two B747-400Fs, and nine of the latest generation Boeing 747-8Fs. The new generation 747-8 Freighter offers an increased payload capacity of 130 tons on a single flight and can accommodate cargoes up to 45 meters in length. AirBridgeCargo's services are also complemented by express and regional services, operated with three Boeing 737-400s.

### ABC's all-Boeing fleet offers a number of important customer benefits:

- Access to maindeck cargo capacity across AirBridgeCargo's entire global network
- 747: nose-door loading for oversized cargo and priority loading
- 747: separate cargo compartments with temperature settings of between 4°C to 29°C
- 747: lower CO<sub>2</sub> emissions

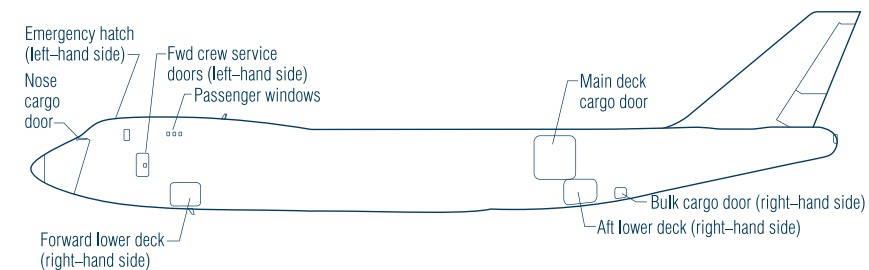
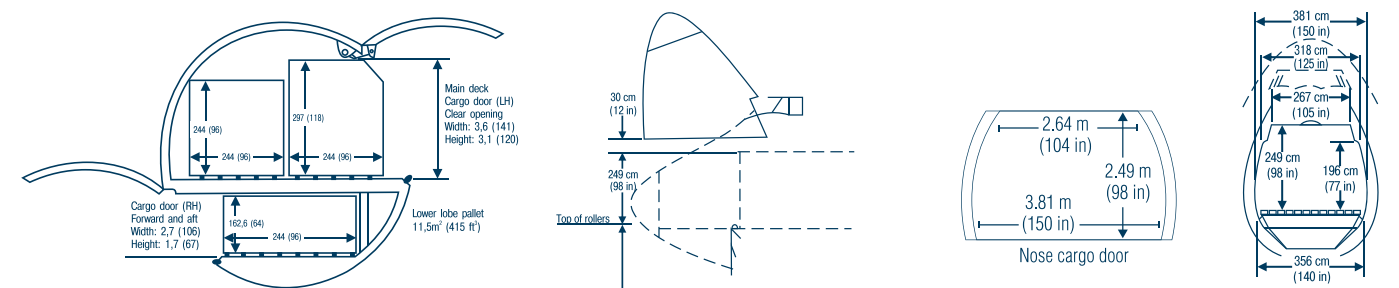
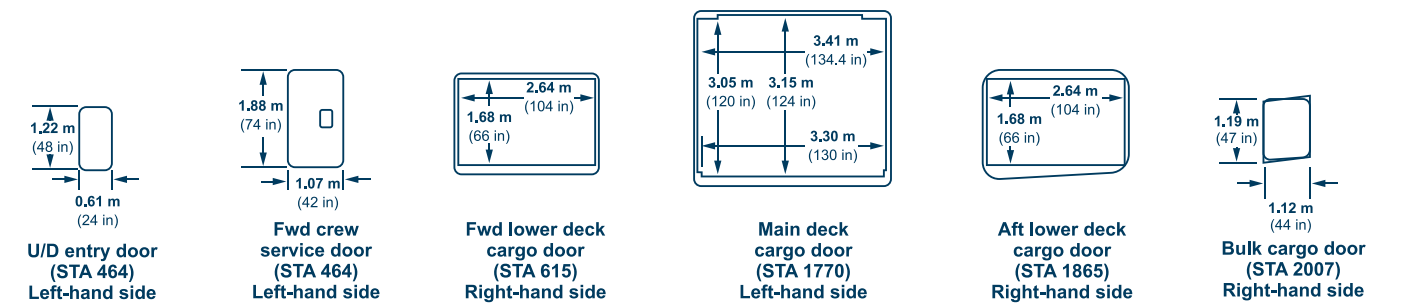
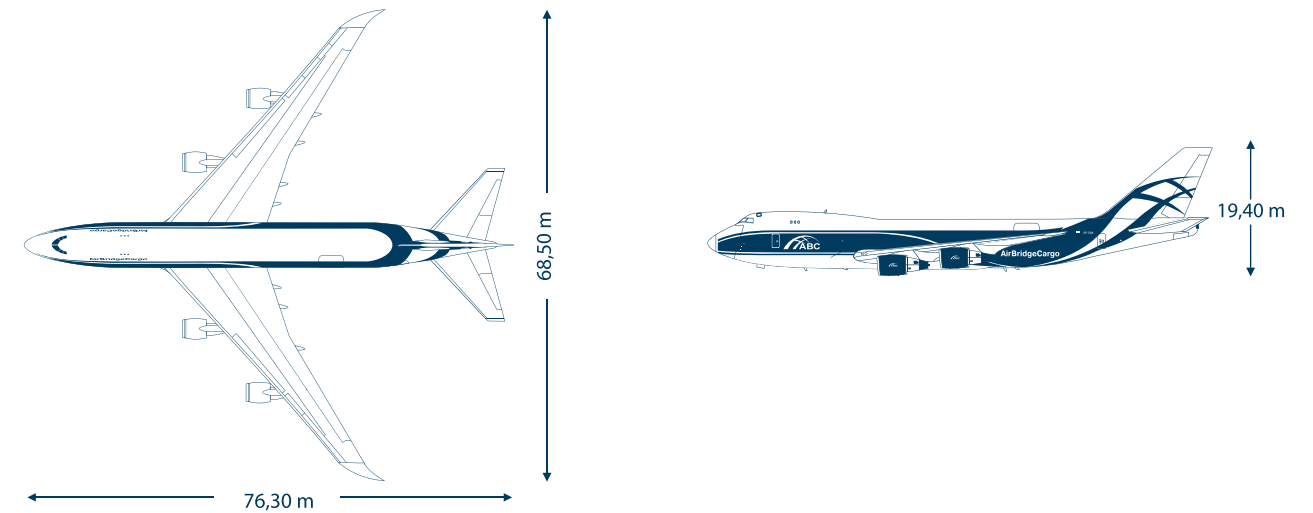

### PYB

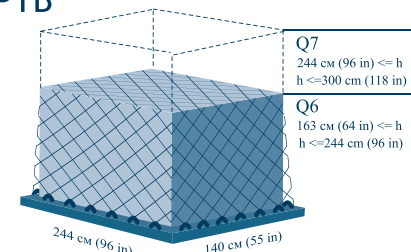

### PGA/PGF

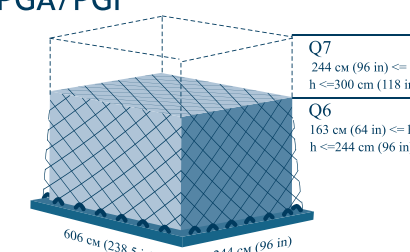

### AKE

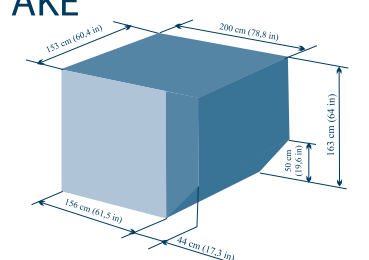

## Loading dimensions of B747-400

Maximum takeoff weight: 412.770 kg | 910,000 lb | Maximum landing weight: 296.200 kg | 653,000 lb

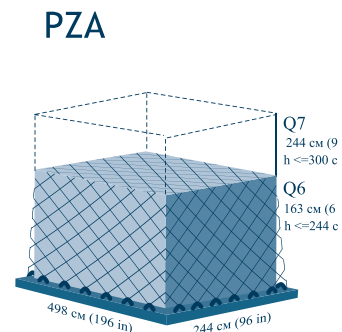
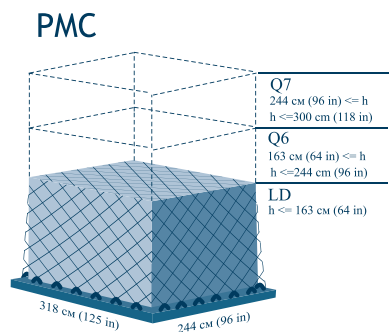
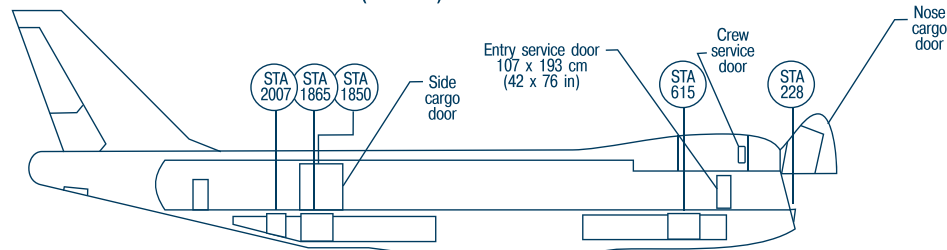
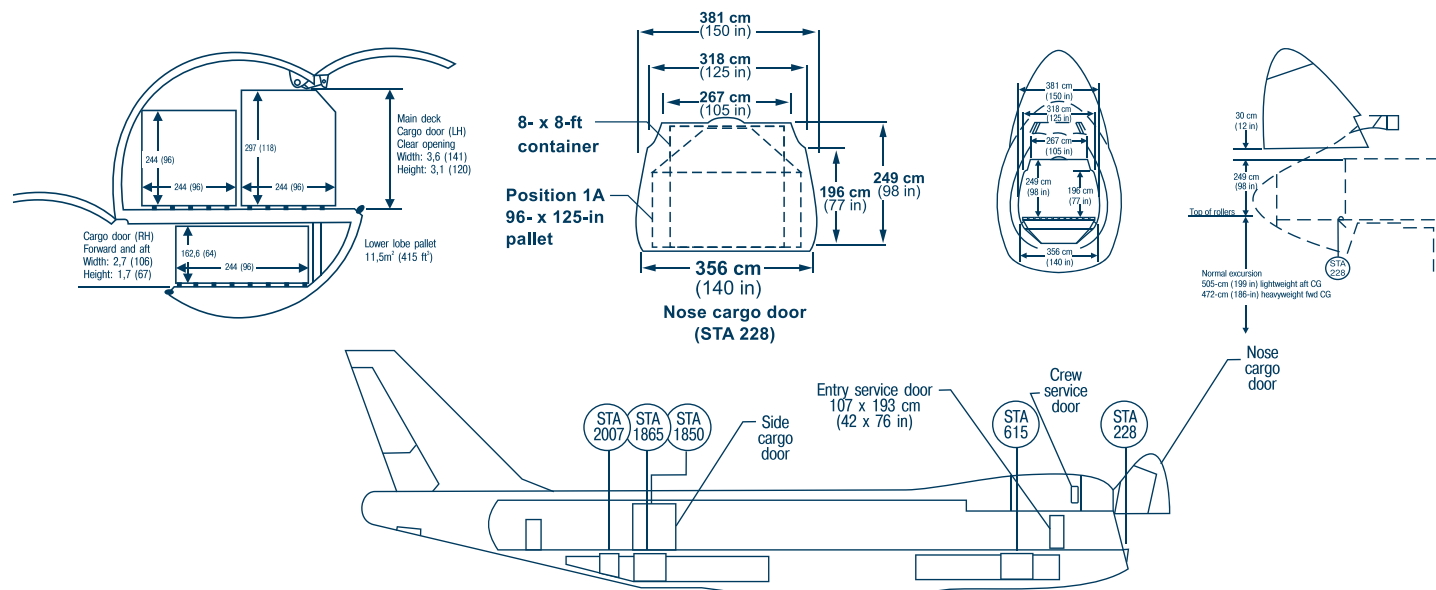
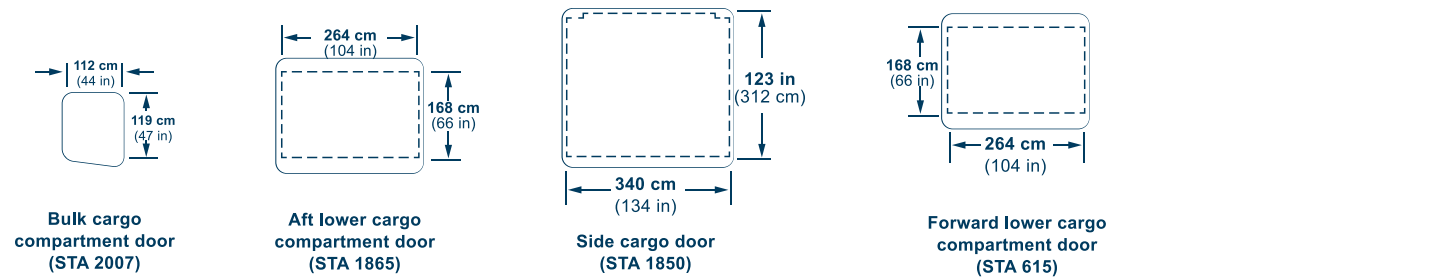
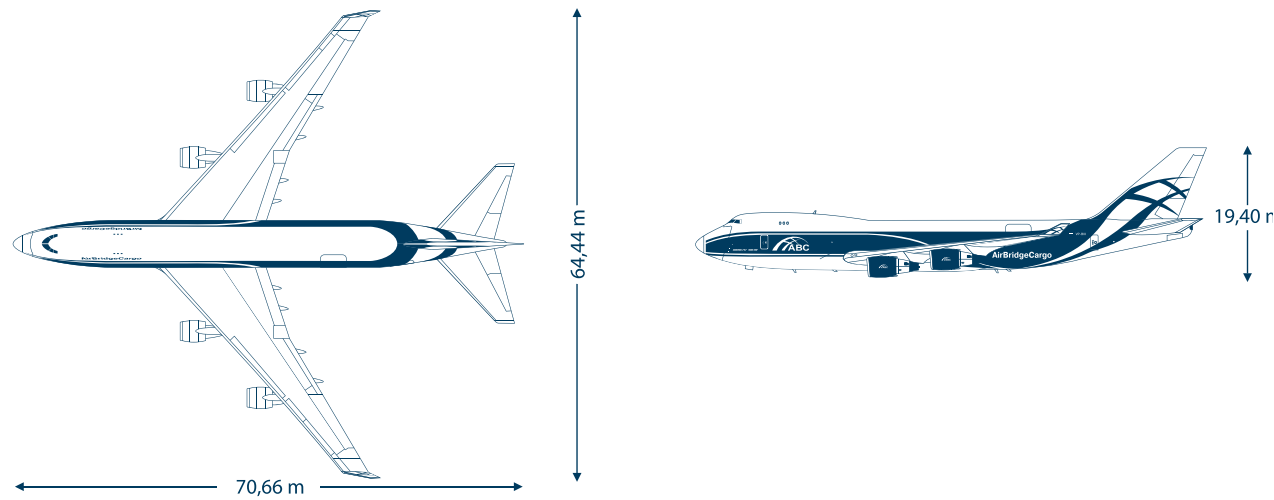

## Loading dimensions of B737-400SF

Maximum takeoff weight: 65.090 kg | 143,500 lb | Maximum landing weight: 55.338 kg | 122,000 lb

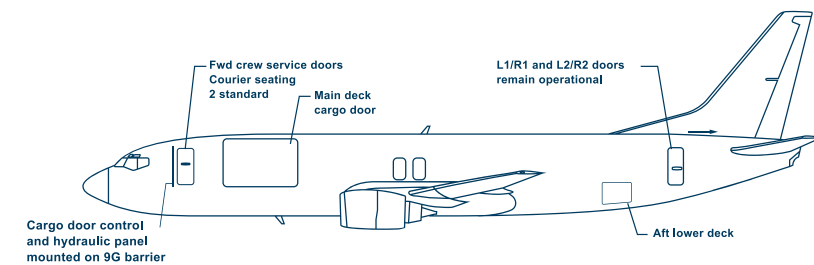
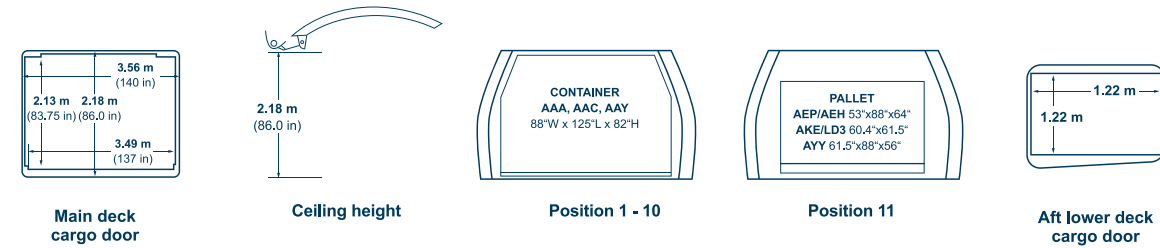
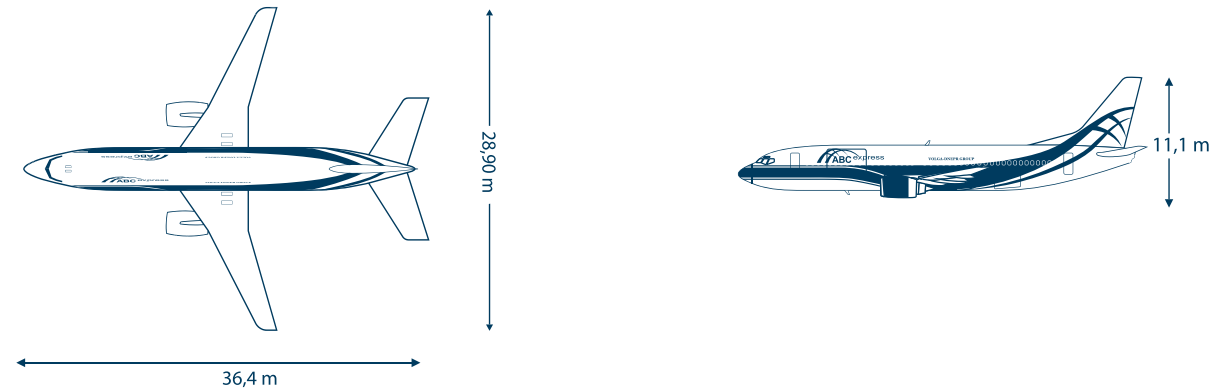

Cargo volume		B747-400	B747-8F	B737-400SF
Main Deck Volume	m <sup>3</sup> (ft <sup>3</sup> )	607,7 (21,462)	692,7 (24,462)	121,5 (4,289)
Pallets, total number	q-ty	30	34	10+1
Lower Hold Volume	m <sup>3</sup> (ft <sup>3</sup> )	158,5 (5,600)	150,9 (5,300)	-
Bulk	m <sup>3</sup> (ft <sup>3</sup> )	14,7 (520)	14,0 (496)	-



 You like knowing there's possibilities in every direction.

AirBridgeCargo's extensive network provides customers with the opportunity to connect their production and consumption centers in the most efficient way. Its hub network model, with flight connectivity in Moscow, offers a wide choice of origin and destination cities and enables customers to access connections within a 48-hour cargo delivery time, including cargo handling.

**Connecting customers to the world's largest cargo markets**

In Asia, the airline's network covers China, Japan, South Korea, Singapore, Vietnam and Taiwan. Currently, AirBridgeCargo performs over 60 weekly flights from its online stations in Asia with further connections to Europe, Middle East and the United States, both via the airline's hub in Moscow and directly.

The airline's global network is complemented by the scheduled flights of ABC's interline partners and extensive trucking services on all continents.





## You like investing in what matters.

Quality has been the cornerstone of AirBridgeCargo's operations since day one and this understanding goes hand-in-hand with reliability, safety and security. ABC strictly follows and supports its own and the air cargo industry's highest standards in order to guarantee:

- **Flight safety, ABC's highest priority.** The airline's safety programme is implemented under its corporate policy of flight safety management and aviation accident prevention, based on ICAO's accident prevention manual and strict internal standards. The airline is an official IOSA Operator.
- **On-time performance (OTP)** - developing 'best-in-class' OTP for customers is another daily focus for ABC, which operates a high 'Delivered-as-Promised' index of over 80% across its global network, and an even higher achievement level on certain routes. At present the airline is among the top 5 industry leaders for this indicator, according to the independent Cargo iQ measurement.
- **Cargo safety and security** is achieved by stringent internal company processes for every stage of the cargo delivery process, managed centrally at ABC's Moscow hub.

As part of its continuous drive for service improvement, as well as security and quality enhancement, the airline actively participates in IATA, the Cool Chain Association, TAPA and Cargo iQ (former Cargo 2000), and supports all of the initiatives introduced by these leading industry organizations.

### Investing in our people

ABC's global team of experienced air cargo professionals unites over 900 employees around the world, and brings together local market knowledge and expertise with a global business understanding of how to consistently deliver value to ABC's customers. The airline combines the ambitious young talent within Volga-Dnepr Group with the extensive experience of its top industry professionals to achieve a fresh outlook on the industry and customers' current and future needs in order to ensure ABC delivers proactive, dynamic and professional services.

*« We always strive to deliver as promised. My team and I believe in efficiency and personalized, quality customer service. Our customers appreciate that. That's why I love my job. »*







*« At ABC, we work closely together with our customers. I look at every shipment individually, and make the best decision in your interest. That's why I love my job. »*



## You like working together to go further.

### Supporting customers in Asia

Asia has always been the core market within AirBridgeCargo's business since the very start of its operations back in 2004. From then onwards the airline has successfully grown its market share in the region by providing its customers with efficient and timely connections to Europe, Russia and USA. With first emphasis on China as being the driver of the Asian growth, ABC has later on made its footprint in Japan, South Korea, Vietnam, Singapore and Cambodia by expanding its network to international airports to guarantee development of its customers' business.

For the last 12 years AirBridgeCargo has been solidifying its sales forces by establishing 11 ABC offices to support customers in this growing region with China taking the leading role among all the

countries (8 on-line stations with offices). Apart from that for off-line sales the company has chosen GSA agents with proven reputation to guarantee delivery solutions where and when needed. Commercial organizational structure in Asia with centralized management functions in joint Volga Dnepr Groups' offices enables to provide customers with a full range of logistics solutions using the Volga Dnepr's 'cargo supermarket' concept. Customers' trust in Asia enabled the airline to be recognized as the 'Best all-cargo carrier' by Asian Freight and Supply Chain Awards 2014, 'Best Overall Carrier of the Year 2015' by Payload Asia Awards, 'Best All-Cargo Airline' by Asian Freight, Logistics and Supply Chain (AFLAS) Awards and 'Media Award of the Year' by the Payload Asia Awards with in 2016.





### AirBridgeCargo Airlines in China

- Operating to/from China since 2004
- 6 online stations: Shanghai, Hong Kong, Beijing, Chengdu, Zhengzhou, Chongqing
- 20 flights from Shanghai, 17 flights from Hong Kong, 7 flights from Beijing, 6 flights from Chengdu, 8 flights from Zhengzhou, 3 flights from Chongqing
- Trucking service within China ex ABC China online stations
- Fast and effective connections to Europe and USA within 48 hours, including cargo handling
- Direct services to Russia
- Direct services to the USA
- 5 dedicated ABC sales offices

AirBridgeCargo was the first cargo airline to launch a freighter service from Beijing in 2004.

### AirBridgeCargo Airlines in Japan

- Operating to/from Japan since 2007
- 4 flights from Tokyo (NRT) per week
- Trucking service within Japan
- Fast and effective connections to Europe and USA within 48 hours, including cargo handling
- Dedicated ABC sales office in Tokyo

### AirBridgeCargo Airlines in South Korea

- Operating to/from South Korea since 2010
- 6 flights from Seoul (ICN) per week
- Fast and effective connections to Europe and USA within 48 hours, including cargo handling
- Dedicated ABC sales office

### AirBridgeCargo Airlines in Singapore

- Operating to/from Singapore since 2015
- 4 flights from Singapore (SIN) per week
- Fast and effective connections to Europe and USA within 48 hours, including cargo handling
- Dedicated ABC sales office

### AirBridgeCargo Airlines in Vietnam

- Operating to/from Hanoi since 2015
- 3 flights from Hanoi (HAN) per week
- Fast and effective connections to Europe and USA within 48 hours, including cargo handling
- Dedicated ABC sales office





## Products & Services for customers in Asia

The excellent operating advantages of ABC's freighter fleet, the performance of the airline's highly-skilled personnel, and constant improvements of its internal processes enable the airline to carry all types of air cargo in full compliance with global industry standards. It offers customers additional solutions, including:

### Oversized cargo and AOG services

Custom-built air charter and end-to-end logistics solutions based on Volga-Dnepr Group's 25 years of expertise in unique, heavyweight and oversized cargo transportation.

- ABC's modern fleet of freighters with nose door cargo loading capabilities for quick and efficient handling (max. load capacity - 130 tons)
- Certified and trained staff across the entire ABC network
- Qualified handling procedures and compliance with IATA regulations and international standard
- Vehicle transportation:
  - » on the Lower and Main Deck of the aircraft for both palletized and RO/RO (roll on- roll off) options
  - » Standard Operating Procedure for prototype cars
  - » Transportation of hybrid vehicles (with lithium batteries)
  - » Racing car transportation
- Aerospace cargo solutions:
  - » Carriage of all commercial aircraft engines and spares. Close cooperation with aircraft and engine manufacturers to ensure correct handling and loading as well as for technical support

You like knowing you're in good hands.



- » Extensive experience of satellite systems transportation
- » Carriage of small aircraft and aircraft parts
- » AOG spare parts transportation with reduced acceptance time options, and expedited pick-up at destination
- Ground Handling Operational Support Team – tailored solutions for outsized and heavy freight:
  - » Personalized approach to logistical solutions, including design & manufacture of frames for loading and transportation, packaging, delivery to gateways/airports of departure
  - » Door-to-door solutions according to customer's requirements
  - » Technical on-site (manufacturer) inspection and consultation
- Priority booking, capacity guarantee, safe transport of Dangerous Goods and reliable on-time delivery
- 3D computer modeling for load planning of complex shipments
- Possibility of cargo attendance
- Shipment visibility at each stage of transportation coordinated by ABC Customer Service supported by online Track & Trace at [www.airbridgecargo.com](http://www.airbridgecargo.com)
- Proven transportation and logistics solutions to remote regions of the world







## Live animals

- Full compliance with IATA AVI regulations and other relevant international standards
- Controlled temperature zones to ensure the comfort, safety and wellbeing of the animals onboard
- Special handling facilities at every gateway for a smooth and qualified handling with authorized access for approved staff only
- Attention to detail - from horse stalls or kennels, ventilation and stocking densities to documentation and communication. ABC will provide full information well in advance of the transportation concerning export and import requirements (including permits), veterinary health inspection, quarantine regulations, trans-shipment requirements or cargo restrictions
- Highest priority for booking and cargo loading as well as quick transit times. All handling and transport processes are adapted to the special requirements of the animals being carried
- Cargo attendants accompanying live animals onboard to control animal health and wellbeing
- Live Animal Advisory specialists
- Assistance with all documentation and IATA Live Animal Regulations' requirements
- Cooperation with local authorities to ensure fast and efficient processes at origin and destination
- Possibility to rent special transport containers including horse stalls and kennels
- More than 10 years of experience, including the safe transportation of racehorses, dolphins, whales, elite breeding stock, cattle, tigers and bears

## Dangerous Goods

- Full compliance with IATA DG Regulations and other relevant international standards as well as ABC's internal security standards
- Fully equipped to handle and deliver all classes of IATA Dangerous Goods and the ability to provide tailored solutions
- Licensed for the transportation of dangerous goods class 1 (explosives) and class 7 (radioactive)
- Smooth and qualified handling procedures at every gateway
- Adjustable temperature-controlled zones onboard
- Carriage of lithium batteries (RLM) with UN3090 PI 968; Section IA and UN3091/3091 PI969 Section
- Transportation of hybrid vehicles with lithium-ion battery engines
- Separate handling away from incompatible substances
- Possibility of obtaining exemptions and approvals for carriage of dangerous goods, e.g. prototypes of radioactive goods
- Handling services provided by certified and trained staff across the entire ABC network in accordance with national requirements







« Even the most sensitive pharmaceutical shipments are safe with us. Our extensive experience and safety standards allow you to have a peace of mind and entrust your special requirements cargo with ABC. That's why I love my job. »

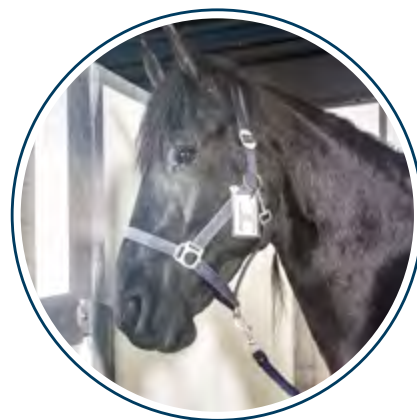

## Pharma

- Temperature monitoring and control onboard the aircraft, on the ramp and in the warehouse to ensure an intact cool chain
- Transportation of different types of commodities and preserving the product quality and integrity of all time & temperature sensitive products
- Temperature-controlled ground handling facilities at the majority of stations throughout the ABC network (cool and ambient temperature facilities)
- Separate storage of perishable products, Dangerous Goods and pharma shipments
- Guarantee that shipments (e.g. CAT scanner) and installation teams arrive at the destination at the same time
- Special packaging solutions from certified in-house packaging providers
- Transportation of active containers across the entire ABC network and availability beyond the airport to minimize temperature fluctuation
- Highest priority for booking and cargo loading
- Special handling procedures and, if required, shorter handling times for specific shipments
- ABC support to ensure each shipment conforms with the industrial and governmental regulatory requirements, including IATA PCR Chapter 17
- Thermo-trucks for temperature-controlled storage of transit shipments in SVO
- Installation of cool cells at ABC's SVO hub in Moscow to cater for the needs of pharmaceutical shipments with passive temperature control packaging
- CEIV Pharma certificate
- Possibility of temperature data logger onboard the 747 aircraft
- Specially-trained and certified staff to manage the handling and transportation of pharmaceutical and healthcare products
- Thermal blankets to protect the temperature integrity of large palletized shipments

## Additional services for cargo to Russia

- ABC aviation security division present at the airport
- Choice of any GHA at Moscow SVO hub
- Preliminary cargo declaration; customs-cleared cargo is ready for pick-up within 4 hours ("Priority SVO")
- Support with customs clearance in SVO on request

\* Varies from station to station. Please contact your local ABC office for more details.





## Hub facilities

ABC's Moscow hub at Sheremetyevo International Airport features modern equipment in each warehouse, allowing for the handling of any type of cargo, including valuables, live animals, dangerous goods, heavy weight and oversized cargoes. The cargo terminal facilities have direct access to the airside apron, facilitating a seamless flow of cargo.

- 3 GHAs operating dedicated warehouses
- 20,000m<sup>2</sup> of total warehouse space
- Dedicated zones for special cargo (dangerous goods, temperature-controlled, vulnerable and live animal shipments) and quarantine zones
- Dedicated pharmacy warehouse
- 380m<sup>3</sup> area for temperature-controlled cargo with dedicated temperature zones
- Special cargo equipment: high-loaders for heavy cargo, refrigerated trucks, and dollies for perishable cargo
- Dedicated control staff located in each warehouse
- 24/7 video surveillance (137 cameras) and automated cargo access control system
- 99.98% safety index
- TAPA certified
- Temperature and humidity monitoring and control using certified devices
- Highly-skilled and qualified personnel





## Get in touch with us.

### CHINA

#### HONG KONG

Room 430, 4/F.South Office Block, Super Terminal One  
Hong Kong International Airport,  
Chep Lap Kok, Hong Kong  
Tel.: + 852 2215 3928  
Fax: + 852 2215 3878  
E-Mail: [service.hkg@airbridgecargo.com](mailto:service.hkg@airbridgecargo.com)

#### SHANGHAI

Room 3105, Shanghai Maxdo Center,  
8 Xingyi Road, Shanghai,  
P.R. China 200336  
Tel.: + 86 21 52080011  
Fax: + 86 21 52080508  
E-Mail: [service.pvg@airbridgecargo.com](mailto:service.pvg@airbridgecargo.com)

#### CHENGDU

Room 302, Shuangliu Airport, New Cargo Terminal  
No. 489 Hangshu Avenue, Chengdu Int'l Airport  
Chengdu, Sichuan Province, 610202  
Tel.: +86 28 8520 7491  
E-Mail: [service.ctu@airbridgecargo.com](mailto:service.ctu@airbridgecargo.com)

#### BEIJING

Room 2006B, Air China Plaza, No 36 xiaoyun Road  
Chaoyang District,  
Beijing 100027.PRC  
Tel.: + 86 10 8447 5936/37/38  
Fax: + 86 10 8447 5935  
E-Mail: [service.pek@airbridgecargo.com](mailto:service.pek@airbridgecargo.com)

#### ZHENGHOU

RM525 Domestic Cargo Terminal, Xin Zheng Inter-  
national Airport Zheng Zhou,  
He Nan Province,P.R.China 451162  
Tel.: +86 371 6851 2201  
E-Mail: [service.cgo@airbridgecargo.com](mailto:service.cgo@airbridgecargo.com)

### JAPAN

#### TOKYO

Onarimon Yusen Bldg 9F 3-23-5 Nishi-Shinbashi,  
Minato-ku, Tokyo 105-0003  
Tel.: + 81 3 5777 4025  
for service enquiries:  
E-Mail: [service.nrt@airbridgecargo.com](mailto:service.nrt@airbridgecargo.com)  
for sales enquiries:  
E-Mail: [sales.jpn@airbridgecargo.com](mailto:sales.jpn@airbridgecargo.com)

#### SINGAPORE

##### SINGAPORE

Room 238, Level 2, Core F, SATS AirFreight Terminal 3  
105 Airport Cargo Road  
Singapore 819462  
Tel.: +65 6214 9424  
E-Mail: [service.sin@airbridgecargo.com](mailto:service.sin@airbridgecargo.com)

### TAIWAN

#### TAIPEI

Orient Air G.S.A. Co., Ltd.,  
General Sales Agent of AirBridgeCargo,  
3 Floor, No 16, Section 1, Nan-King East Road,  
Taipei, Taiwan  
Phone: 886 2 2100 8800  
Fax: 886 2 2100 8811  
E-Mail: [williamchen.tpe@worldwidegsa.com](mailto:williamchen.tpe@worldwidegsa.com)

### SOUTH KOREA

#### SEOUL

Room 604, 6th Floor, Seoul Center Building  
116, Sogong-ro, Jung-gu,  
Seoul, 04533, Korea  
Tel.: +82 2 712 5803  
Tel.: +82 70 4136 5804  
E-Mail: [yb.ha@airbridgecargo.com](mailto:yb.ha@airbridgecargo.com)

### VIETNAM

#### HANOI

Room 343, ALS Cargo Terminal  
Noi Bai International Airport  
Soc Son District  
Hanoi, Vietnam  
Tel.: +84 38501339+84 902421339  
E-Mail: [han.ops@airbridgecargo.com](mailto:han.ops@airbridgecargo.com)





Space for your ideas.



---

---

---

---

---

---

---

---

---

---

---

---

---

---

---

---

---

---

---

---

---

---

---

---

---

---

---

---

---

---

---

---

---

---

---

---

---

---

---

---

---

---

---

---

---

---

---

---

---

---

---

---

---

---

---

---

---

---

---

---





*That's why we love our job.*

[www.airbridgecargo.com](http://www.airbridgecargo.com)